

CUSTOMER		
ORDER No.		
PART No.		
OUR ORDER No.		
FRAME SIZE		
KW.	RPM.	
Hz	PHASE	
VOLTS	POLES	
BRGS.	DE.	NDE.
MOTOR NETT WT.		Kg.
SPECIAL REMARKS		

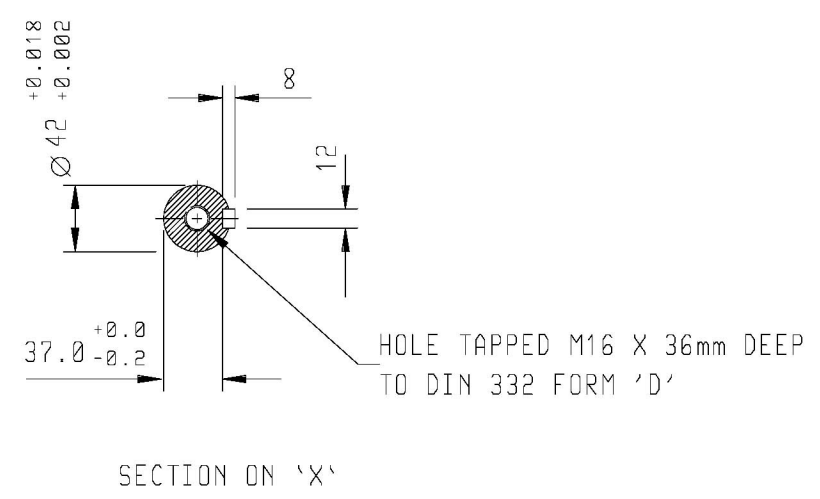
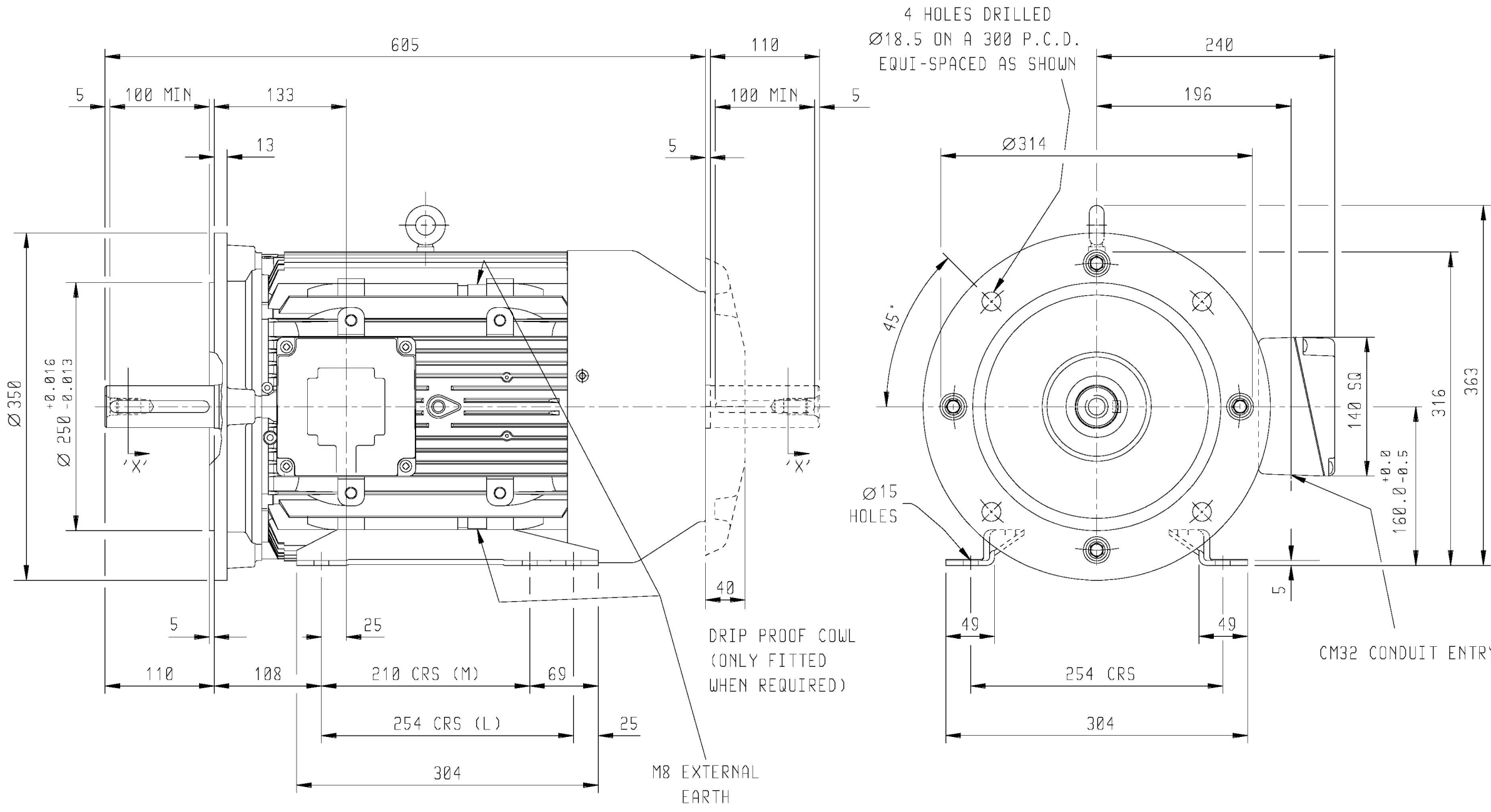

DRAIN HOLES:- WHEN TERMINAL BOX IS MOVED FROM STANDARD POSITION
 THEY WILL NEED TO BE PLUGGED AND RE-LOCATED ELSEWHERE - IF REQUIRED

TERMINAL BOX POSITION : - CAN BE ARRANGED AT EITHER 9, 12 OR 3 O'CLOCK BY MOVING FEET.
 STANDARD TERMINAL BOX POSITION IS 3 O'CLOCK AS SHOWN.

CONDUIT ENTRIES:- TERMINAL BOX CAN BE ROTATED AT 90° INTERVALS
 (CONDUIT ENTRY POSITION SHOWN FOR ILLUSTRATION ONLY).

ALL DIMENSIONS IN MILLIMETRES.

FIRST ANGLE
 PROJECTION

**BROOK
 CROMPTON**

SHEET SIZE A3	TITLE	OUTLINE DIMENSION DRAWING W ALUMINIUM TOTALLY ENCLOSED FAN COOLED 160M/L FRAME FOOT AND 'D' FLANGE MOUNTED MOTOR	NAME	DATE
	DRAWN			
	CHECKED			
	SCALE	1 : 5		

DRG. No.	
DRG. REF.	
REVISION:	DATE